

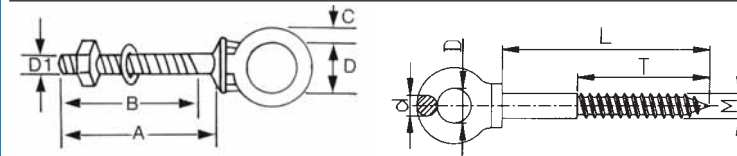

CÁNCAMOS CON ROSCA MÉTRICA

KEY	D1 mm	A mm	B mm	C mm	D mm	Peso g
FMA	M6	40	34	5	12	28
FMB	M6	60	54	5	12	31
FMC	M6	80	70	5	12	35
FMD	M8	80	70	6	14	64
FME	M8	100	90	6	14	71
FMF	M10	100	88	8	16	126
FMI	M12	120	105	10	18	239



CÁNCAMOS CON ROSCA PARA MADERA

KEY	descripción	Ø mm	L total	L mm	T mm	D mm	O mm	Peso g
FMK	cáncamo con rosca de tirafondos	6	87	60	30	13	5	25
FML	como FMK, con anilla Ø 6x40mm	6	87	60	30	13	5	58
FMM	cáncamo con rosca de tirafondos	8	88	60	40	13	6	37
FMN	como FMM, con anilla Ø 8x45mm	8	88	60	40	13	6	108
SAN	tirafondo con ojo delgado de 3mm	5	54	31	24	5,3		9
SAO	tirafondo con ojo delgado de 4mm	6	66	45	35	6,3		13
SAP	tirafondo DIN 444	5	45	34	20	5	6	7
SAQ	tirafondo DIN 444	6	47	34	20	6	7	11
SAR	tirafondo DIN 444	8	58	41	30	8	9	22

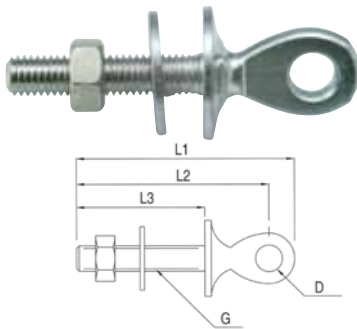

OJILLOS CON ROSCA MÉTRICA - AISI 316

KEY	G mm	L1 mm	L2 mm	L3 mm	B1 mm	B2 mm	D mm	PESO g
SLG	M6	53	46	30	25	4	6,5	13
SLB	M6	83	76	60	25	4	6,5	21
SLC	M8	65	58	35	25	5	8,5	33
SLH	M8	110	104	80	25	5	8,5	50
SLE	M10	87	75	50	30	6	10,5	82
SLF	M10	137	125	100	30	6	10,5	110

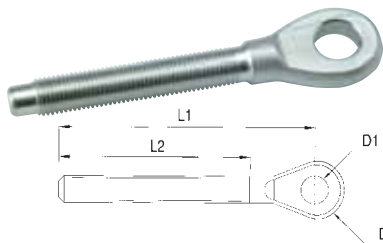

OJILLOS CON ROSCA MÉTRICA - AISI 316

KEY	KEY rosca der.	KEY rosca izqu.	G	D1 mm	D2 mm	L1 mm	L2 mm	PESO g
FPA	FPJ	M5	5,5	12	63	41	9	
FPB	FPK	M6	6,5	14	65	47	15	
FPC	FPL	M8	8,5	17	78	57	31	
FPD	FPM	M10	10,5	22	90	63	51	
FPE	FPN	M12	13,0	25	110	80	101	

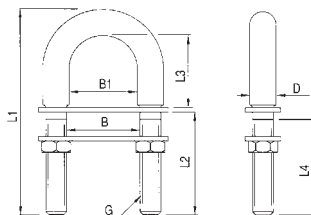

CÁNCAMOS "U" - AISI 316

KEY	G	L1 mm	L2 mm	L3 mm	L4 mm	B mm	B1 mm	D mm	Peso g
FTC	M6	91	53	35	53	31	27,5	7,8	72
FTD	M8	82	39	40	39	27,5	25	10,3	111